

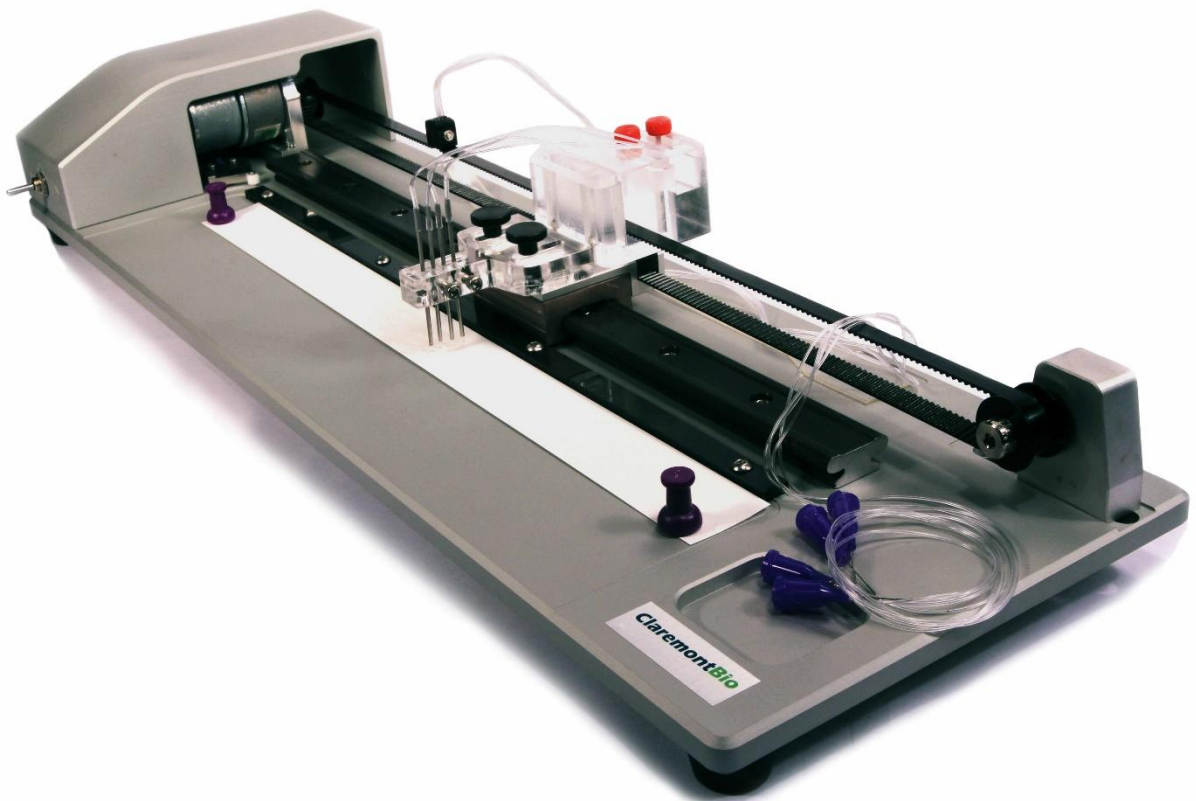

# Automated Lateral Flow Reagent Dispenser (ALFRD) Instruction Manual



1182 Monte Vista Ave. Suite #11 • Upland, CA 91786  
Phone: 909-920-3887 • Fax: 909-946-1132

## Specifications

Approx. Dimensions (L x W x H): 457 x 146 x 75 mm  
(excluding power supply and syringe pump)

Approx. Weight: 2.5 kg (excluding power supply and  
syringe pump)

Power: Adjustable to AC/DC Adapter  
120 VAC to 3-12 VDC

Dispense Area (L x W): 322 x 65 mm

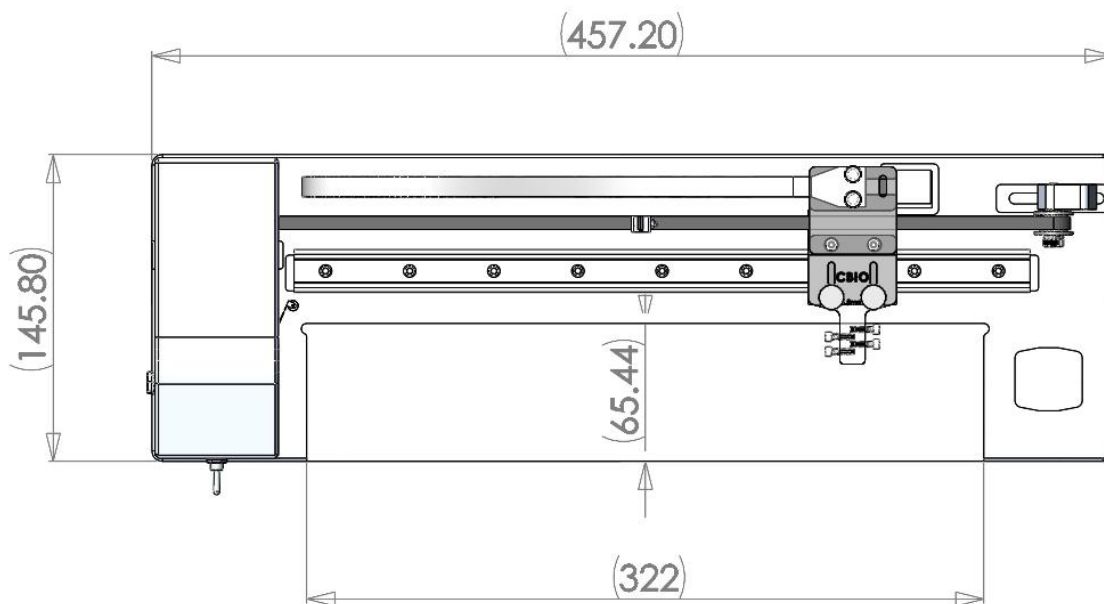

Inner diameter of dispensing tubing and tip: 0.25mm

## Instructions for Use

1. Plug in and turn on Automated Lateral Flow Reagent Dispenser (ALFRD) unit and external syringe pump.
2. Program syringe pump flow rate according to manufacturer's instructions.
  - a. See Figures 2 and 3 in Appendix A for recommended flow rates.
  - b. ClaremontBio recommends using the Chemyx Fusion 200 Syringe Pump ([www.chemyx.com/syringe-pumps/fusion-200](http://www.chemyx.com/syringe-pumps/fusion-200))
3. Select voltage on power supply. A range of 4.5 - 6V is recommended.
  - a. If a faster head speed is desired, a power supply can be connected in lieu of the provided power supply; however, 12V is the maximum voltage that can be used for the ALFRD.

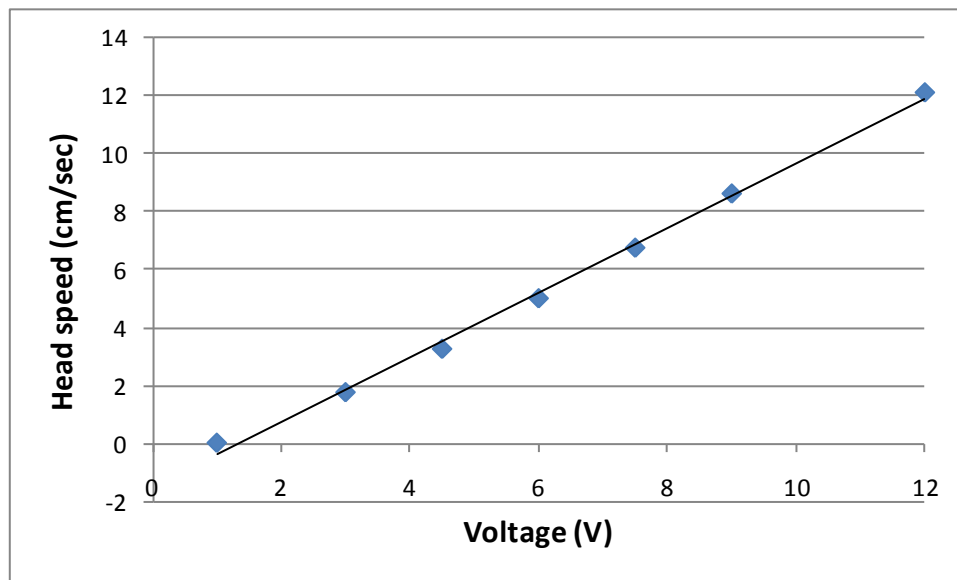

**Figure 1 Voltage dependence on head speed:** Voltage of ALFRD varied from 0 to 12V. Distance travelled = 30 cm.

4. Secure dispense tips into desired placement slot on dispense tip head using provided Allen wrench.
  - a. For best results, position tips very close to the membrane surface, without direct contact (unless contact is desired).
    - i. Actual height is dependent on membrane type and thickness.

- b. Tips positioned too high may result in liquid droplet formation or uneven lines.
- c. To test positioning, place membrane on dispense table and initiate switch to cause table to move. Drag on membrane will be apparent.
  - i. Once desired height is established, it may be helpful to mark position on metal post of dispense tip with a permanent marker.

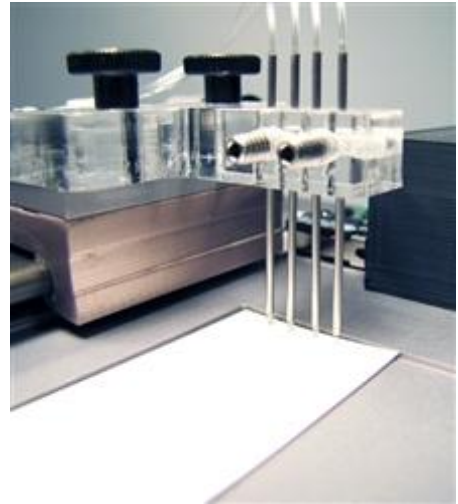

5. Once dispense reagents have been prepared, remove air bubbles prior to use in ALFRD (i.e. quick centrifugation, nitrogen air purge).
  - a. A volume of 200  $\mu$ l or greater is recommended.
  - b. When solution is running out during dispensing, lines will appear thinner and may produce varying results.
6. Draw up each solution into a syringe, taking care to minimize air bubbles.
7. Attach tubing to blunt syringe needle and secure filled syringes on syringe pump according to manufacturer's instructions.
8. Turn on syringe pump to prime solution(s) through tubing and dispense. Turn off pump and wipe away residual liquid.
9. Secure membrane onto ALFRD dispense table using magnets.
10. Turn on syringe pump, followed immediately by dispense table switch.
11. Once dispense tips have reached the end of the table and stopped, turn off syringe pump.
12. Remove membrane from table.
13. Return dispense tips to their original position by reversing the table switch.
14. Wipe off any residual liquid from table.
15. Repeat for each membrane as necessary.

## **Recommended Cleaning and Storage Procedure**

1. Following reagent dispensing, purge lines of remaining fluid.
2. Rinse several times with dI water.
3. Follow with several washes of 1-10% bleach (if desired).
4. Flush out bleach with dI water.
5. Purge out water and store reagent lines dry.
6. To avoid cross-contamination of reagents, it is recommended to designate one reagent dispense tip / tubing per reagent (cat # 07.811.01).

## Appendix A

### I. Flow Rate (ml/min)

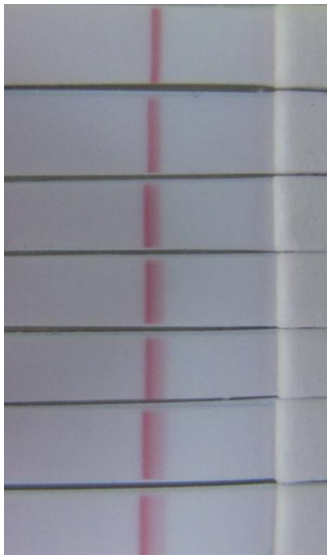
		<u>Vol./time</u>	<u>Vol./distance</u>
A		0.20 ml/min	3.24 µl/cm
B		0.25 ml/min	4.05 µl/cm
C		0.30 ml/min	4.85 µl/cm
D		0.35 ml/min	5.66 µl/cm
E		0.40 ml/min	6.47 µl/cm
F		0.45 ml/min	7.28 µl/cm
G		0.50 ml/min	8.09 µl/cm

**Figure 2: 4.5v** used for dispensing 2 mg/ml Human IgG + 5% Ethanol onto nitrocellulose with ALFRD. Syringe pump flowrate varied from 0.20ml/min (A) to 0.50ml/min (G). High affinity interactions may create an intense front edge, resulting in a capture line that appears less homogeneous; therefore, a lower flow rate may be optimal (A or B), depending upon specific application.

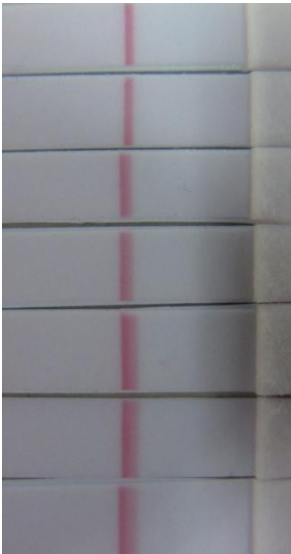
		<u>Vol./time</u>	<u>Vol./distance</u>
A		0.20 ml/min	2.33 µl/cm
B		0.25 ml/min	2.91 µl/cm
C		0.30 ml/min	3.50 µl/cm
D		0.35 ml/min	4.08 µl/cm
E		0.40 ml/min	4.66 µl/cm
F		0.45 ml/min	5.24 µl/cm
G		0.50 ml/min	5.83 µl/cm

**Figure 3: 6v** used for dispensing 2 mg/ml Human IgG + 5% Ethanol onto nitrocellulose with ALFRD. Syringe pump flowrate varied from 0.20ml/min (A) to 0.50ml/min (G). High affinity interactions may create an intense front edge, resulting in a capture line that appears less homogeneous; therefore, a lower flow rate may be optimal (A or B), depending upon specific application.

## II. Calculating flow rate to achieve desired volume per distance

Desired Volume per distance	<b>X</b>	Head Speed	<b>=</b>	Flow Rate
[uL/mm]		[mm/sec]		[uL/sec]

Ex 1: To achieve 0.5 uL/mm (using setting for “1mL BD plastic syringe”)		
If using voltage (head speed):	Set flow rate at (in uL/sec)	Set flow rate at (in mL/min)
@3V (~17.5mm/sec)	8.75 uL/sec	0.525 mL/min
@4.5V (~32.5mm/sec)	16.25 uL/sec	0.975 mL/min
@6V (~50mm/sec)	25 uL/sec	1.5 mL/min

Ex 2: To achieve 0.25 uL/mm (using setting for “1mL BD plastic syringe”)		
If using voltage (head speed):	Set flow rate at (in uL/sec)	Set flow rate at (in mL/min)
@3V (~17.5mm/sec)	4.38 uL/sec	0.263 mL/min
@4.5V (~32.5mm/sec)	8.13 uL/sec	0.488 mL/min
@6V (~50mm/sec)	12.5 uL/sec	0.750 mL/min

Ex 3: To achieve 0.05 uL/mm (using setting for “1mL BD plastic syringe”)		
If using voltage (head speed):	Set flow rate at (in uL/sec)	Set flow rate at (in mL/min)
@3V (~17.5mm/sec)	0.88 uL/sec	0.053 mL/min
@4.5V (~32.5mm/sec)	1.63 uL/sec	0.098 mL/min
@6V (~50mm/sec)	2.5 uL/sec	0.15 mL/min

Inner diameter of dispensing tubing and tip: 0.25mm

### III. Maximum and Minimum Flow Rates for Fusion 200 pump vs. syringe brand and size

Syringe Size	I.D. Inner Diameter (mm)	Minimum Flow Rate (in uL/hr)	Minimum Flow Rate (in ul/sec)	Minimum Flow Rate (in ml/min)	Maximum Flow Rate (in uL/hr)	Maximum Flow Rate (in ul/sec)	Maximum Flow Rate (in ml/min)
1mL	4.78	0.17	4.86E-05	2.91E-06	1.09E+05	30.30	1.82
3mL	8.66	0.57	1.59E-04	9.56E-06	3.58E+05	99.45	5.97
5mL	12.07	1.11	3.10E-04	1.86E-05	6.96E+05	193.20	11.59
10mL	14.50	1.61	4.47E-04	2.68E-05	1.00E+06	278.82	16.73
20mL	19.13	2.80	7.78E-04	4.67E-05	1.75E+06	485.31	29.12
30mL	21.69	3.60	1.00E-03	6.00E-05	2.25E+06	623.89	37.43
60mL	26.72	5.46	1.52E-03	9.10E-05	3.41E+06	946.81	56.81

Syringe Size	I.D. Inner Diameter (mm)	Minimum Flow Rate (uL/hr)	Minimum Flow Rate (in ul/sec)	Minimum Flow Rate (in ml/min)	Maximum Flow Rate (in uL/hr)	Maximum Flow Rate (in ul/sec)	Maximum Flow Rate (in ml/min)
0.5uL	0.103	1.00E-04	2.78E-08	1.67E-09	5.06E+01	0.01	0.00
1uL	0.146	1.60E-04	4.44E-08	2.67E-09	1.02E+02	0.03	0.00
2uL	0.206	3.20E-04	8.89E-08	5.33E-09	2.03E+02	0.06	0.00
5uL	0.326	8.10E-04	2.25E-07	1.35E-08	5.07E+02	0.14	0.01
10uL	0.48	0.00176	4.89E-07	2.93E-08	1.10E+03	0.31	0.02
25uL	0.73	0.00407	1.13E-06	6.78E-08	2.54E+03	0.71	0.04
50uL	1.03	0.00811	2.25E-06	1.35E-07	5.06E+03	1.41	0.08
100uL	1.46	0.0163	4.53E-06	2.72E-07	1.02E+04	2.83	0.17
250uL	2.3	0.04047	1.12E-05	6.75E-07	2.53E+04	7.02	0.42
500uL	3.26	0.08131	2.26E-05	1.36E-06	5.07E+04	14.09	0.85
1mL	4.61	0.16259	4.52E-05	2.71E-06	1.01E+05	28.18	1.69
2.5mL	7.28	0.40548	1.13E-04	6.76E-06	2.53E+05	70.28	4.22
5mL	10.3	0.81167	2.25E-04	1.35E-05	5.06E+05	140.69	8.44
10mL	14.57	1.62414	4.51E-04	2.71E-05	1.01E+06	281.52	16.89
25mL	23.03	4.05783	1.13E-03	6.76E-05	2.53E+06	703.36	42.20
50mL	32.57	8.11599	2.25E-03	1.35E-04	5.06E+06	1406.77	84.41



# USER NOTES

# USER NOTES

# USER NOTES



**Claremont BioSolutions, LLC**

1182 Monte Vista Ave.

Suite 11

Upland, CA 91786

Toll-free: 1-855-855-1777

Main: 909-920-3887

Fax: 909-946-1132

Email: [info@claremontbio.com](mailto:info@claremontbio.com)

Website: [www.claremontbio.com](http://www.claremontbio.com)