



# FUSION 4000-X OEM

## USER MANUAL

### INTELLECTUAL PROPERTY

All Intellectual Properties, as defined below, owned by or which is otherwise the property of Chemyx Inc. or its suppliers relating to the Chemyx syringe pumps, including but not limited to, accessories, parts or software relating thereto (Chemyx Syringe Pumps), are proprietary to federal and state laws, and international treaty provisions. Intellectual Property includes but is not limited to, inventions (patentable or unpatentable), patents, trade secrets, copyrights, software, firmware, computer programs, and related documentation and other works of authorship. Moreover, you agree that you will not, and will not attempt to, modify, prepare derivative works of, reverse engineer, disassemble the Chemyx syringe pumps, decompile or otherwise attempt to create source code from the related software/firmware. No title to or ownership in Intellectual Property is transferred to you. All applicable rights of the Intellectual Property shall remain with Chemyx and its suppliers.

# Table of Contents

Safety Information	3
Product Overview	4
Data Sheet	5
Loading a Syringe	6
Pump Control by Computer	7
Controller Programs	9
Commands	10
Pump Maintenance	11
Syringe Pump Accessories	12
Warranty and Repair Information	13
Appendix A: Syringe Volume/Diameter Reference Table	14

# Safety Information

Please read the following safety precautions to ensure personal safety and operational longevity of the Chemyx syringe pump. Chemyx is not responsible for the equipment if used in a manner not specified by the manufacturer; warranty coverage provided by the equipment may be dropped as a result.

**CHEMYX PRODUCTS ARE NOT APPROVED FOR CLINICAL USE ON HUMANS.**

## Use Proper Power Supply

Chemyx is not responsible for the use of power supplies outside the stated electrical specifications or failure to switch the power converter from 220V to 110 V while in the 220V environment or vice versa.

## Ground Product

The product should be properly grounded.

## Do Not Open The Pump

Warranty coverage will be lost if the pump is opened without authorization from Chemyx. Do not touch any electrical connectors on or in the product.

## Do Not Operate With Suspected Failures

Even though the pump can operate at extremely fast speeds, the user must determine the proper flow rate for any given application. For instances, pumping at 90 mL/min using a 20-gauge needle will cause stalls and/or potential bursting of the syringe. Chemyx is not responsible for any damage that might result from situations similar to the example above.

## Pinch Hazard

Do not place fingers between the pusher block and the end block while the pump is running.

## Observe all Warning labels on Product

Read all labels on the product to ensure proper usage.

## Chemyx is not Responsible for Syringe Damage

The user is responsible for wetting ground glass syringes and setting and tightening the safety collar/bar appropriately.

# Product Overview

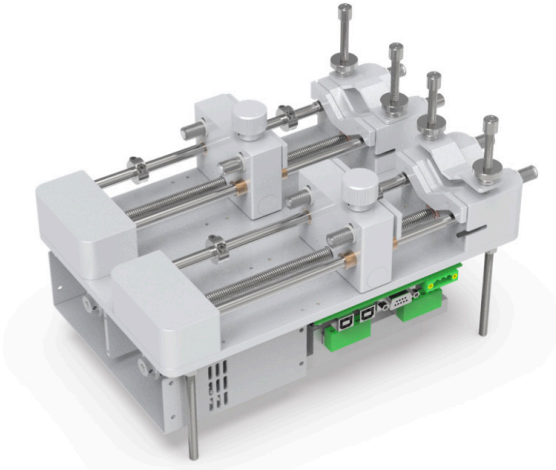

## Fusion OEM 4000-X

The Fusion OEM 4000-X syringe pump comes with a dual drive system that allows two independent pumping channels to be controlled for simultaneous infusion and withdrawal at same/different flows.

## Fusion OEM 4000-X

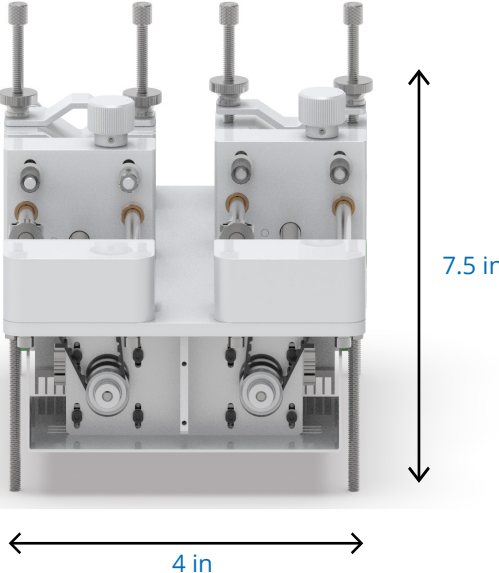
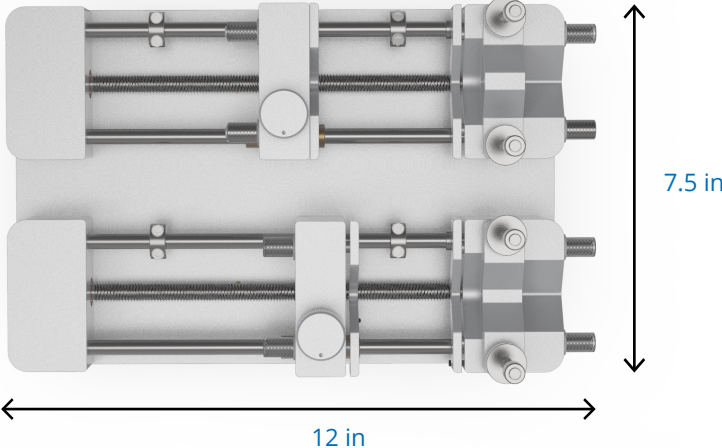

# Fusion 4000-X OEM Module Data Sheet

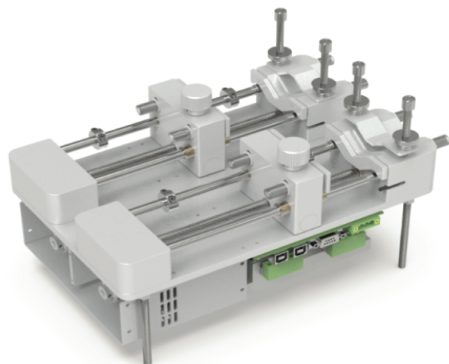

The Fusion 4000-x OEM syringe pump comes with a dual drive system that allows two independent pumping channels to be controlled for simultaneous infusion and withdrawal at same/different flows.

## TECHNICAL SPECIFICATIONS

<b>Mode</b>	Infuse & Withdraw
<b>Accuracy</b>	$\pm < 0.35\%$
<b>Reproducibility</b>	$\pm < 0.2\%$
<b>Syringe Size (Min/Max)</b>	0.5 $\mu$ L to 100mL
<b>Syringe Type</b>	Plastic and Glass
<b>Syringe Flow Rates</b>	See Syringe Library for Min & Max Flow Rates on Website
<b>Minimum Flow Rate</b>	0.0001 $\mu$ L/min (with 0.5 $\mu$ L syringe)
<b>Maximum Flow Rate</b>	170.5 mL/min (with 100mL syringe)
<b>Linear Force</b>	80lb (36kg)
<b>Maximum Pressure</b>	See Max Pressure on Website
<b>Display</b>	None
<b>Connectivity</b>	USB-B, RS232 and TTL Ports
<b>System Dimensions</b>	11.3 x 7.1 x 7.5 inches (28.7 x 18 x 9 cm)
<b>Power</b>	24V DC 4.6A
<b>Weight</b>	15lbs (7kg)
<b>Motor Drive</b>	1.8° Stepper Motor with Micro-stepping
<b>Step Resolution</b>	0.0293 $\mu$ m/step
<b>Operating Temperature</b>	4°C to 40°C (40°F to 104°F)
<b>Storage Temperature</b>	-10°C to 70°C (14°F to 158°F)
<b>Humidity</b>	20% to 80% RH, non-condensing
<b>Installation Category</b>	II
<b>Regulatory Compliance</b>	CE, RoHS, REACH, FCC

# Loading a Syringe

The OEM can accommodate one syringe. The volume of the syringes can vary from a minimum of 0.5  $\mu$ L up to a maximum of 60 mL. Syringes of any material (e.g., glass, plastic, stainless steel, etc.) can be used; however, some use cases may require syringes that are more accurate and durable.

## FUSION 4000-X OEM

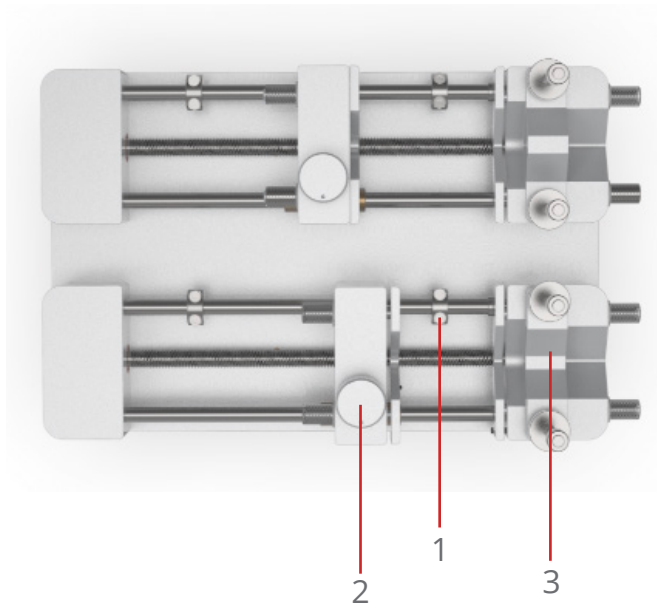

1. If necessary, move and tighten the infusion safety collar (see Adjusting the Safety Collar).
2. While pressing in the lock-release button, slide the pusher block all the way to the left.
3. Pull up on the spring-loaded syringe clamp and place the syringe in one of the channels of the syringe-holder block. Ensure that the flange of the syringe barrel is flush against the edge of the syringe-holder block. Slowly lower the syringe clamp to secure the syringe in place.

## Motor Power

The Fusion 4000-X OEM pump motor can generate up to a maximum of 80lbs linear force. Some syringes made of more fragile materials may not be able to withstand the full linear force of the pump.

# Pump Control by Computer

The OEM syringe pumps can be controlled with an external computer using an RS232 serial connection.

## Cable Requirements

Two types of connections are available for external computer control: DB9 and USB, cables for each are available for purchase through Chemyx (call 1-281-277-5499 or visit [www.chemyx.com/contact-us](http://www.chemyx.com/contact-us)).



DB9 Serial Cable (Male-to-Female)



USB-A to USB-B cable

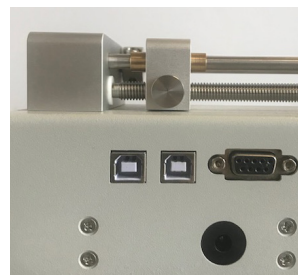

TTL Connection

For the DB9 serial connection, a Male-to-Female DB9 cable must be used. Do not use any “null modem,” “crossover,” or “crossed-over” cables. The cable can be of any length up to 50 ft; however, the speed of the connection is often detrimentally affected at lengths over 15 ft.

For a USB serial connection, a USB-A to USB-B cable should be used. The maximum possible length of a single USB cable is 15 ft; however, USB cables should be less than 10 ft for optimum performance. Multiple USB cables can be chained together to make a longer connection as long as the hub connecting each individual cable is connected to a power supply.

A USB-to-DB9 serial adapter can be used to connect a DB9 serial connection to the USB port on a computer.

All of these connections require the proper drivers to be installed on the computer. Typically, most current operating systems already contain drivers for the USB serial connection. They may also already have drivers for the DB9 serial connection. USB-to-DB9 adapters typically need to have a USB-to-serial driver installed. For more information on downloading and installing drivers please visit [www.chemyx.com/support](http://www.chemyx.com/support).

## Connecting

Most computer operating systems (e.g., Windows, macOS, Linux, etc.) have built-in terminal programs that can be used to type in the commands that run the pump. On Windows XP and earlier, HyperTerminal can be used to control the pump. On macOS and Linux, the screen command in Terminal can also be used to control the pump. There are also numerous third-party programs for serial connections that exist for each operating system that may be easier to use and provide more features. A third-party program will be necessary to connect with computers running Windows Vista and later.

For tips on operating the built-in terminal programs and information on available third-party programs, please visit [www.chemyx.com/support](http://www.chemyx.com/support).



# Fusion OEM 4000-X Cable Connectors

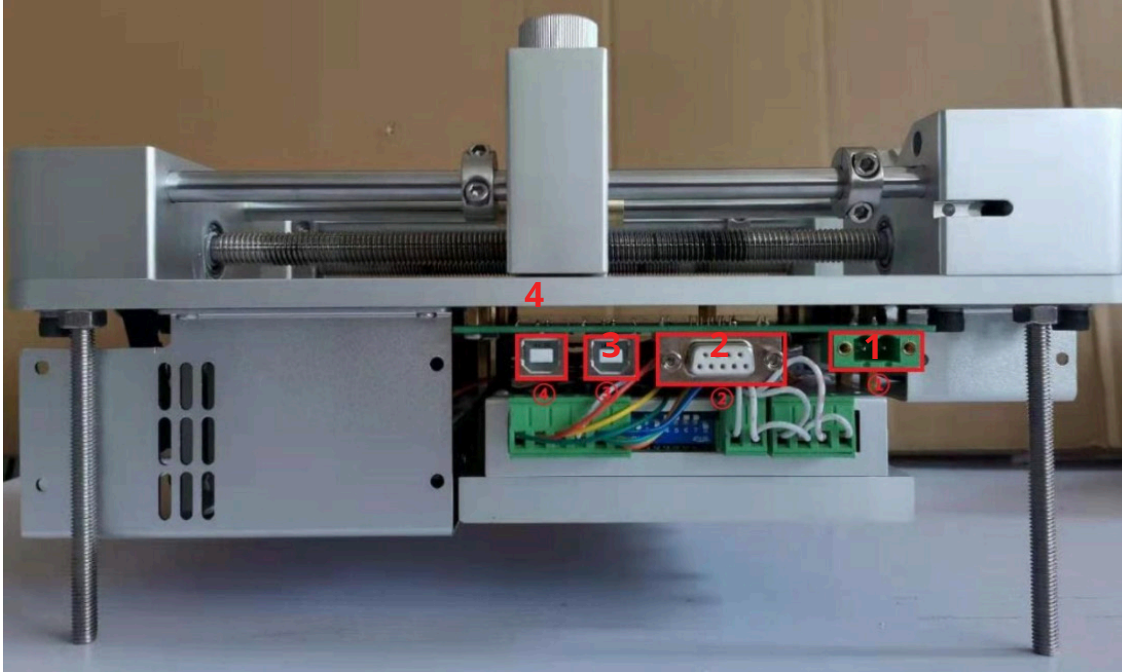

1 Power 2 RS232 3 USB 4 Foot switch

Hit foot switch once, both pumps will start; hit twice, both pumps will stop

# Fusion OEM 4000-X Computer Connections

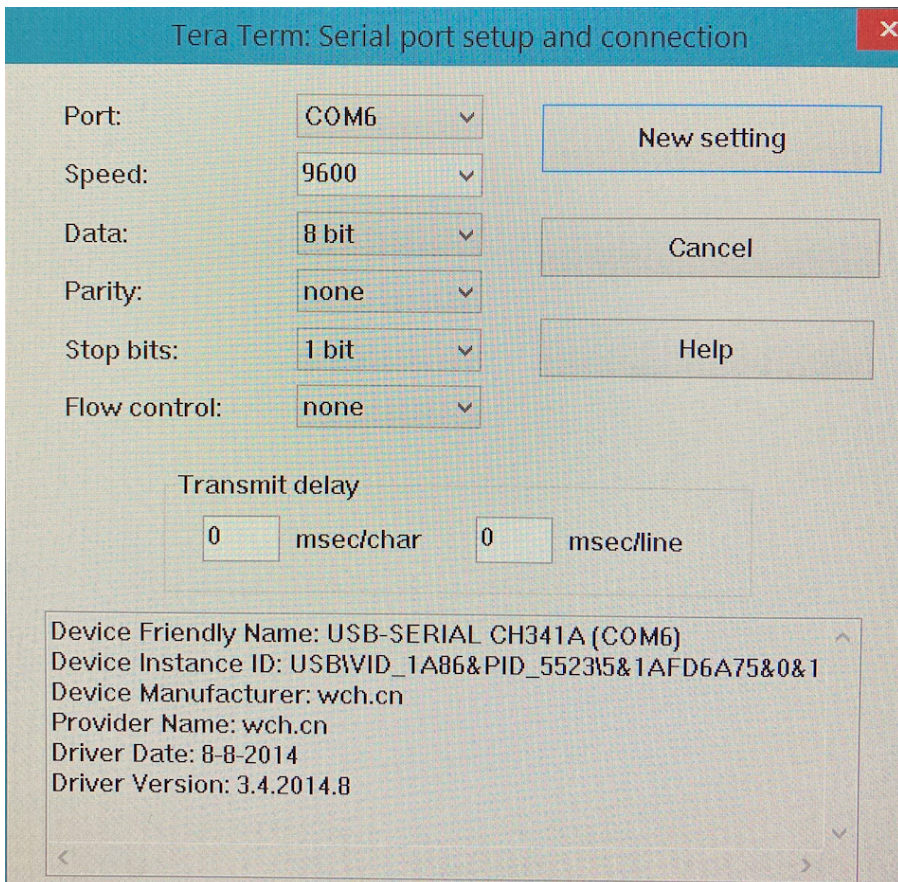



# Chemyx Pump Controller Programs

In addition to the manual control of the pumps through a terminal, Chemyx provides pump controller programs as an unsupported open-source applications written in Python, a LabVIEW package, and a MATLAB package. More information on these tools can be found on the website at [www.chemyx.com/support](http://www.chemyx.com/support).

Chemyx provides free downloads for LabVIEW™ and MATLAB™ as a courtesy to our customers. This service is not supported by Chemyx, all customers are responsible for solving any technical issues related to LabView and MATLAB computer control.

## COM Port Settings

Regardless of the operating system being used, the terminal program controlling the serial connection should use the following connection settings:

Baud Rate	9600 or 38400
Data Bits	8
Parity	None
Stop Bits	1
Flow Control	None

## Baud Rate

The baud rate setting for the serial connection must match the baud rate set in the pump settings GUI (See Baud Rate in System Settings). Generally, the pump should be set to use the higher baud rate (38400) if a USB-only connection is used. However, if a DB9-only or USB-to-DB9 connection is used, the baud rate must be set to 9600. Typically, if the baud rate is not set correctly, there will be garbled or no response to any command

The baud rate is the rate at which information is transferred through the serial connection. This rate is often limited by the type of serial connection used. The OEM syringe pump provide two possible baud rates: 9600 and 38400. Serial connections using the USB-B port on the back of the pump should use the faster baud rate of 38400. Serial connections using the DB9 port on the back of the pump will need to use the slower baud rate of 9600.

See Pump Control by Computer for more information.

# Quick Start Guide - Commands

RS232 Protocol/Commands

\* Explanation of command function is located after command name\*

RS232 Comport Settings: All system from 11/1/2010

Bits per seconds - 38400

Data bits - 8

Parity - None

Stop bit - 1

Flow control - None

Note: Settings are same for both D9 and USB comports

help

-----  
help - Show Help Information  
-----

Movement Commands  
-----

start -Pump Run

stop -Pump Stop

pause -Pump Pause

restart -Pump Restart  
-----

Setting Commands  
-----

set units [xxx] -Pump Set Units(0,1,2,3 or ml/min,ul/hr)

set diameter [x.x] -Pump Set Diameter

set rate [x.x,x.x,...] -Pump Set Rate

set volume [x.x,x.x,...] -Pump Set Volume

set delay [xxx] -Pump Set Delay

set time [x.x,x.x,...] -Pump Set Time(will calculate rate)

set mode [x...] 1 Sets withdraw function  
-----

**set units** set unit increments for fluid deliver (i.e, ul/min, ul/hr, ml/min, ml/hr)

**set diameter** set syringe inner diameter measurement - this tells the pump what syringe size you are using. Example: 10ml syringe ID is 14.5mm, so you would enter 14.5

**set rate** set 'flow rate' or flow speed at which you want to dispense/extract fluid

**set volume** set volume delivery - this is how much volume you wish to dose to or extract from specified source

**set delay** If you want the system to run at a certain point in your setup (i.e. after, 10-30 seconds, 1, 5, 10 minutes, etc.) you may set a time delay for appropriate time for pump to begin run

set time set volume as a function of time. Example: users wants to

**run the** pump to run over 5

minutes (it will do so, but it will only administer as much volume as it can within that 'time' parameter

set mode to 1 for withdraw function / to reset infuse, set mode to 0  
-----

Status Commands  
-----

read limit parameter -Pump Return Max/Min Volume & Rate

dispensed volume -Pump Return Volume Dispensed

elapsed time -Pump Return Time Elapsed

pump status -Pump Return System Status  
-----

Additional Optional Commands  
-----

hexw2 [units] [mode] [diameter] [volume] [rate] [delay]

- Sends All Settings

hexw2 [units] [mode] [diameter] [volume] [rate] [delay] start

- Sends All Settings and Starts

## IMPORTANT

**ALWAYS connect RS232 and Power supply BEFORE powering on the OEM Module!**

# Pump Maintenance

## Lubricating the Pump

Pump lubrication is the most important part of regular pump maintenance. Proper lubrication ensures long service life, smooth flow performance, and protection against corrosive lab fumes. The pump may not be adequately cleaned and lubricated if the following occur: (1) grinding sounds are coming from the lead screw; (2) the block release button decouples under the load before the pump stalls; or (3) the pump stalls with increased frequency.

## Lubrication Instructions

1. Clean contact surfaces with a clean cloth. Remove any debris on the lead screw and the guide rods.
2. Apply lubricant along the length of the lead screw and the guide rods.
3. Press the block-release button and slide the pusher block to the left edge.
4. Run the pump end-to-end without a syringe to work the lubricant into the components.

Pump lubrication should be performed every three months.

## Approved Lubricants

- Engine/motor oil
- Silicone oil
- Machine oil
- Tooling oil or “WD-40”
- Lithium-based grease

Please contact Chemyx call +1 281-277-5499 or email us at [info@chemyx.com](mailto:info@chemyx.com) to confirm the safe use of a different lubricant.

# Syringe Pump Accesories



**Footswitch**

Streamline laboratory operations with this electric foot switch control that lets you start, stop, or pause your Chemyx syringe pump systems—even when your hands are full. The electric foot pedal switch connects seamlessly to computerized pumping programs, and its 10-foot cable connection can be customized for either the Nexus series (DB9 connection) or the Fusion 100/200/4000/6000 and 100-X/200-X/4000-X/6000-X (USB-B connection).



**USB Cable**

Connect your Chemyx syringe pump directly to any computer with this 6-ft USB-B cable. This communication USB cable can connect with any of the Chemyx syringe pump systems to allow full remote control through a variety of automation programs, such as LabVIEW and MATLAB.



**RS232 Cable**

Remotely control your Chemyx syringe pump from any computer with this 6-foot RS232 cable. The RS232 cable ensures a quick and easy setup for seamless device communication with automation software such as LabVIEW and MATLAB to streamline your laboratory workflow. Each end of the RS232 cable connects to a 9-pin port (DB9).

# Warranty and Repair Information

## Warranty Information

Chemyx provides a two-year limited warranty (1) first year for parts and labor (2) second-year for parts only from the shipment date for its pumps against defects in materials and workmanship. Chemyx will repair product that proves defective during its stated warranty period. To get warranty repair the customer is responsible to send the pump to Chemyx.

The foregoing warranty will not apply to damage resulting from:

- ▶ Improper or inadequate maintenance or operation.

---

- ▶ Unauthorized modification or misuse of the product.

---

- ▶ Operation outside the electrical specifications for the product.

---

- ▶ Operation outside the temperature specifications for the product.

---

- ▶ User-induced internal and external contaminations of the instrument.

---

- ▶ Failure to use proper surge protection.

---

- ▶ Improper product return, packaging, and shipping

---

- ▶ Removing serial number from syringe pump

## Repair Information

Chemyx can repair the syringe pump without major damage. You must contact Chemyx Inc by either email or phone before returning the product. Chemyx will issue a Return Authorization (RA) number to you.

You must contact Chemyx (call +1 281-277-5499 or visit [www.chemyx.com/contact-us](http://www.chemyx.com/contact-us)) before returning a product. Chemyx will issue a Return Authorization (RA) number to you.

Return products to:

Chemyx Inc.

10905 Cash Road | Stafford, TX 77477 USA.

## Serial Numbers

The serial number is located on the back, top left corner or center of the pump under a small barcode. Removal of the serial number label will void the warranty.

# Appendices

## Appendix A: Syringe Volume/Inner Diameter Reference

### Chemyx Stainless Steel

Size	Diameter Inner   Outer
6.00 mL	9.5 mm inner   13mm outer
20.00 mL	19.1 mm inner   23 mm outer
50.00 mL	28.6 mm inner   33 mm outer
100.00 mL	35 mm inner   38 mm outer
200.00 mL	44 mm inner   48 mm outer

### BD Glass

Size	Diameter
0.50 mL	4.64 mm
1.00 mL	4.64 mm
2.00 mL	8.93 mm
2.50 mL	8.66 mm
3.00 mL	8.93 mm
5.00 mL	11.73 mm
10.00 mL	14.68 mm
20.00 mL	19.60 mm
30.00 mL	22.70 mm
50.00 mL	28.03 mm
60.00 mL	28.60 mm

### BD Plastic

Size	Diameter
1.00 mL	4.64 mm
3.00 mL	4.64 mm
5.00 mL	12.07 mm
10.00 mL	14.50 mm
20.00 mL	19.13 mm
30.00 mL	21.69 mm
60.00 mL	26.72 mm

### Hamilton Glass

Size	Diameter
0.50 µL	0.10 mm
1.00 µL	0.15 mm
2.00 µL	0.21 mm
5.00 µL	0.33 mm
10.00 µL	0.48 mm
25.00 µL	0.73 mm
50.00 µL	1.03 mm
100.00 µL	1.46 mm
250.00 µL	2.30 mm
500.00 µL	3.26 mm
1.00 mL	4.61 mm
2.50 mL	7.28 mm
5.00 mL	10.30 mm
10.00 mL	14.57 mm
25.00 mL	23.03 mm
50.00 mL	32.57 mm

### Hoshi

Size	Diameter
1.00 mL	4.80 mm
1.00 mL	6.70 mm
2.00 mL	6.70 mm
2.00 mL	9.20 mm
3.00 mL	10.30 mm
5.00 mL	12.20 mm
10.00 mL	15.00 mm
20.00 mL	19.00 mm
30.00 mL	22.50 mm
50.00 mL	25.50 mm
100.00 mL	34.00 mm



## JMC Air-Tite Plastic

Size	Diameter
1.00 mL	4.66 mm
2.00 mL	6.90 mm
2.50 mL	9.10 mm
5.00 mL	12.62 mm
10.00 mL	14.34 mm
20.00 mL	19.68 mm
30.00 mL	22.44 mm
50.00 mL	28.80 mm
100.00 mL	36.68 mm

## Natsume

Size	Diameter
0.25 mL	2.60 mm
0.50 mL	3.20 mm
1.00 mL	4.30 mm
2.00 mL	6.30 mm
3.00 mL	7.30 mm
5.00 mL	9.50 mm

## Nipro

Size	Diameter
1.00 mL	4.71 mm
3.00 mL	9.50 mm
5.00 mL	12.91 mm
10.00 mL	15.40 mm
20.00 mL	19.30 mm
30.00 mL	23.40 mm
50.00 mL	29.00 mm

## Norm-Ject Plastic

Size	Diameter
1.00 mL	4.70 mm
2.50 mL	9.70 mm
5.00 mL	12.48 mm
10.00 mL	15.89 mm
20.00 mL	20.00 mm
30.00 mL	22.50 mm
50.00 mL	28.90 mm

## Popper & Sons Glass

Size	Diameter
0.25 mL	3.45 mm
0.50 mL	3.45 mm
1.00 mL	4.50 mm
2.00 mL	8.92 mm
3.00 mL	8.99 mm
5.00 mL	11.70 mm
10.00 mL	14.70 mm
20.00 mL	19.58 mm
30.00 mL	22.70 mm
50.00 mL	29.00 mm

## Ranfac

Size	Diameter
2.00 mL	9.12 mm
5.00 mL	12.34 mm
10.00 mL	14.55 mm
20.00 mL	19.86 mm
30.00 mL	23.20 mm
50.00 mL	27.60 mm

## SGE Glass

Size	Diameter
25.00 µL	0.73 mm
50.00 µL	1.03 mm
100.00 µL	1.46 mm
250.00 µL	2.30 mm
500.00 µL	3.26 mm
1.00 mL	4.61 mm
2.50 mL	7.28 mm
5.00 mL	10.30 mm
10.00 mL	14.57 mm

## Sherwood Plastic

Size	Diameter
1.00 mL	4.65 mm
3.00 mL	8.94 mm
6.00 mL	12.70 mm
12.00 mL	15.90 mm
20.00 mL	20.40 mm
35.00 mL	23.80 mm
50.00 mL	26.60 mm

## Terumo

Size	Diameter
1.00 mL	4.73 mm
3.00 mL	9.00 mm
5.00 mL	13.04 mm
10.00 mL	15.79 mm
20.00 mL	20.18 mm
30.00 mL	23.36 mm
60.00 mL	29.45 mm

## Terumo Japan

Size	Diameter
1.00 mL	4.73 mm
1.00 mL	6.50 mm
3.00 mL	8.65 mm
5.00 mL	13.00 mm
10.00 mL	15.80 mm
20.00 mL	20.15 mm
30.00 mL	23.10 mm
50.00 mL	29.10 mm

## Top

Size	Diameter
1.00 mL	4.70 mm
2.00 mL	6.40 mm
3.00 mL	9.30 mm
6.00 mL	13.10 mm
12.00 mL	15.40 mm
25.00 mL	21.00 mm
30.00 mL	23.00 mm
50.00 mL	29.00 mm

## Unimetrics

Size	Diameter
10.00 $\mu$ L	0.46 mm
25.00 $\mu$ L	0.73 mm
50.00 $\mu$ L	1.03 mm
100.00 $\mu$ L	1.46 mm
250.00 $\mu$ L	2.30 mm
500.00 $\mu$ L	3.26 mm
1000.00 $\mu$ L	4.61 mm

## Kendall Monoject Plastic

Size	Diameter
1.00 mL	4.65 mm
3.00 mL	8.94 mm
6.00 mL	12.70 mm
12.00 mL	15.90 mm
20.00 mL	20.40 mm
35.00 mL	23.80 mm
60.00 mL	26.60 mm